



Adding Values To Your Living Spaces

2023
SINGLE DOOR LOCKER
LOCKERS
01

SANDER

S
I
N
C
E
2001

Our Brand **Vision**

From Turkey to the World, with **environmental**,
ecological, and national values...

EXPORT TO 26 DIFFERENT COUNTRIES



Since 2001, SANDER, the industry leader, has expanded its production and export volume.

It is a global brand that is continually expanding.

With cubicle manufacture, we specialize in providing comfort to living areas.

"High quality service at an affordable price" has been our motto from the day we opened our doors.

Our enterprise, which operates entirely with local capital and products, generates both employment and significant economic contributions to our country.

A model structure in terms of the significance it places on technology, R&D, design, and human resources.

SANDER, which is a "sustainable" discipline concept, gains an environmental business strategy.

Because of its environmental business strategy, SANDER is a "sustainable" discipline concept. acquires.

SANDER, which continuously decreases its carbon emissions through a regulated follow-up, plans to meet the "zero waste" aim by 2030.

The tagline "Adds value to your living spaces" inspires the design of practical, colorful, and dependable items.

SANDER provides comfort in over 20 nations.



SINGLE DOOR LOCKER

Product Code: 10Z.01.A1

IT'S MODERN

The collection offers dynamic details with its colorful color spectrum from yellow to gray, keeping the areas you need away from monotony. Whatever your living space design, it exceeds your expectations with colorful and imaginative ideas. SANDER single door locker cabinets, as well as wet areas; It delivers aesthetically pleasing, sturdy, and long-lasting usage in high-traffic locations.



Value Adding **Features**

Quality details and advantages;

- Product bodies are made of three distinct materials: HPL (high pressure, 100% water-resistant laminate), CDF (long-lasting, water-resistant durable, hygienic and useful cabinet material), and MDF (Medium Density fiberboard).
- Body MDF Lam (18 mm), doors CDF (12 mm) or HPL (12 mm); body CDF or HPL, doors HP can also be used if desired.
- Manufactured to first-rate MDF Kastamonu Entegre or Yldz Entegre specifications.
- To strengthen the product's water resistance, the bay windows' edge is 0.80 mm thick. The strength of the PVC band is enhanced by tugging it.
- The body, hole, suspension pipe, connection, and minifix points are all CNC machined, and it opens with "zero mistake."
- Cabinet legs with adjustable features, 30x30x2 mm and 10 cm
- It is made of 304 stainless steel. The sections of the adjustable legs are made of plastic.
- There is CNC engraving form numerator on cabinet doors.
- Products have a master (manual) or digital combination lock.
- The goods are made by attaching a plastic grille or by opening a CNC machine.
- Aluminum and stainless steel cabinet handles are produced.
- The locker cabinets' primary materials are covered by a Sander guarantee for three years for MDF, five years for CDF, and ten years for HPL.

The devil is in the details when it comes to high technology.

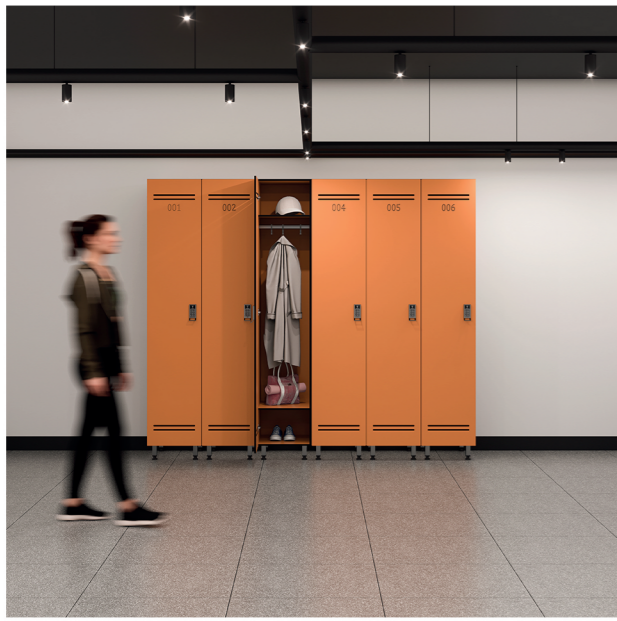

DA 01819
Hinge for 12 mm
Compact Laminate



DA 01209
Plastic Hanger



KD050/45-116



KD050/45-106



KD050/45-115

Kale Digital
Combination Lock



DA 01217

304 Stainless
Steel Handle



DA 01216

Aluminum Handle



DA 01203

Standard Lock



DA 01201

304 Stainless
Steel Leg

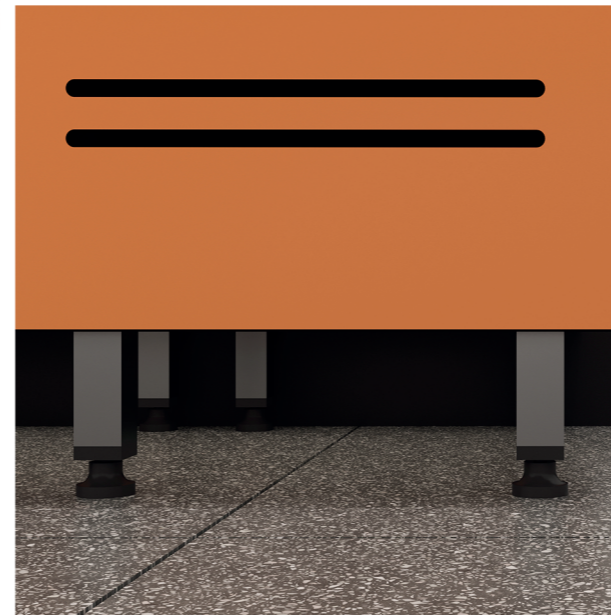

TOP VIEW

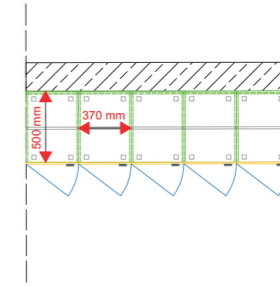

FRONT VIEW

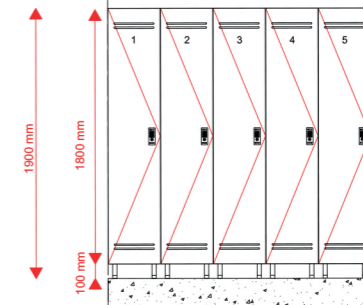

FRONT VIEW

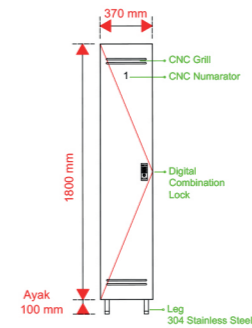

INSIDE VIEW

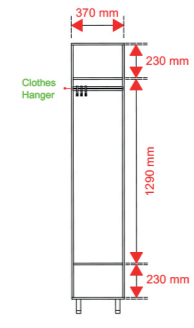

SIDE VIEW

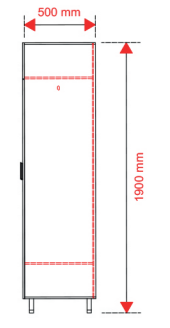

CNC GRILL DETAIL

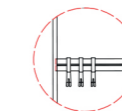

CLOTHES HANGER DETAIL

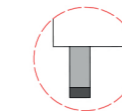

30°/30° 304 STAINLESS STEEL
LEG DETAIL

LOCKER DIMENSIONS
W : 370 mm
D : 500 mm
H : 1900 mm
Lock:
Two alternatives can be used: standard, master and digital lock.
Hinge:
Nickel plated bowl hinge and stainless steel leaf hinge are used.
Numerator:
It is optional to process the Cover Panel with the chosen typeface and font using a CNC MACHINE or an aluminum plate numerator.
Leg:
304 Stainless steel, anti-bacterial plastic floor connection. Adjustable height is 100-150 mm and helps to adapt to the slope of the wet areas in general.
Connections:
All fasteners used in accessories and cubicle assembly are 304 quality stainless steel.

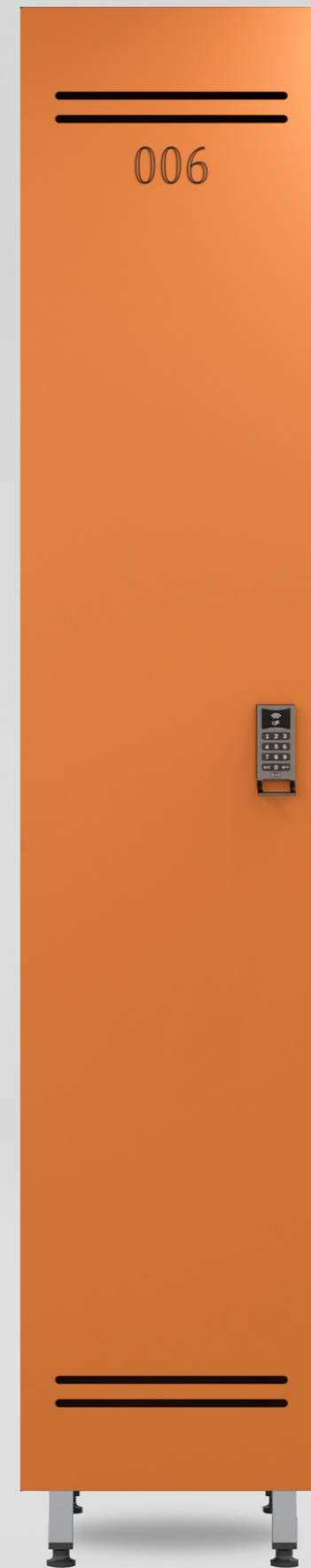
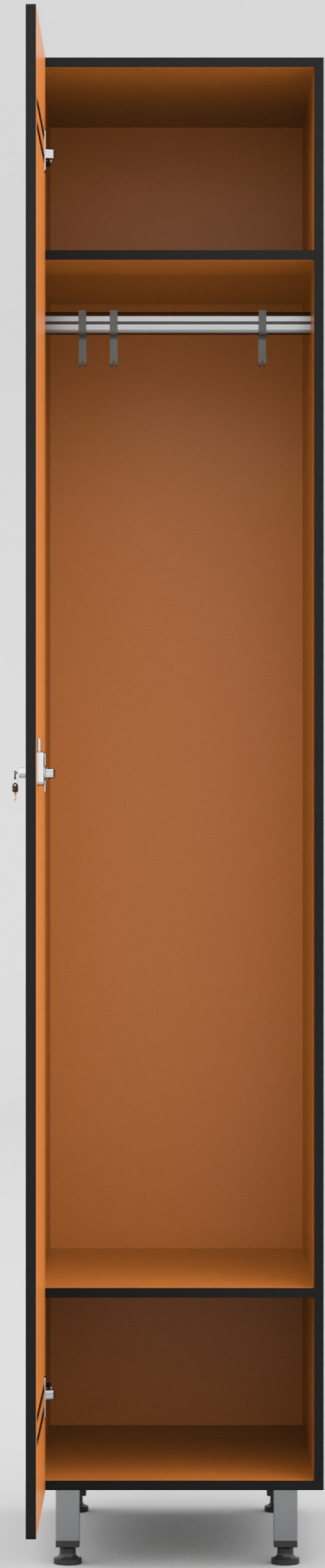

Accessories

LEG

Product Code - DA 01201

- The product has a dimension of 30x30mm and is square in shape.
- Made from 304 grade satin stainless steel.
- The product features antibacterial plastic below the legs.
- The product is compatible with MDF and compact laminate cabinets.



0,272 kg

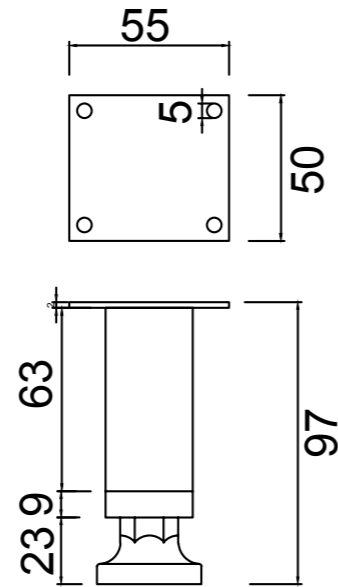

The devil is in the details when it comes to ergonomics.

The plastic under the legs is 10 cm long and adjustable. The carrying capacity is 130 kg.



Master (Manual) System Square Cabinet Lock

Product Code - DA 01201

- Made using first-rate zamak material.
- This product weights 0.050 grams.
- It comes with two folding keys.
- All locks of this sort may be opened using the master lock and a special master key that is sold separately.

 0,050 kg

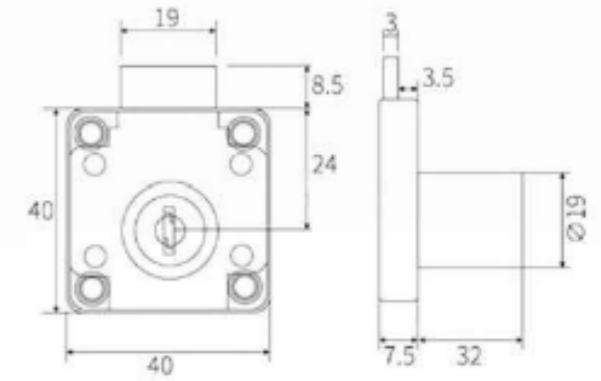

Safety in the details.

The ball key construction makes it extremely tough to open. Users gain trust as a result of this feature.

Kale Digital Lock

Product Code - KD050/45-116

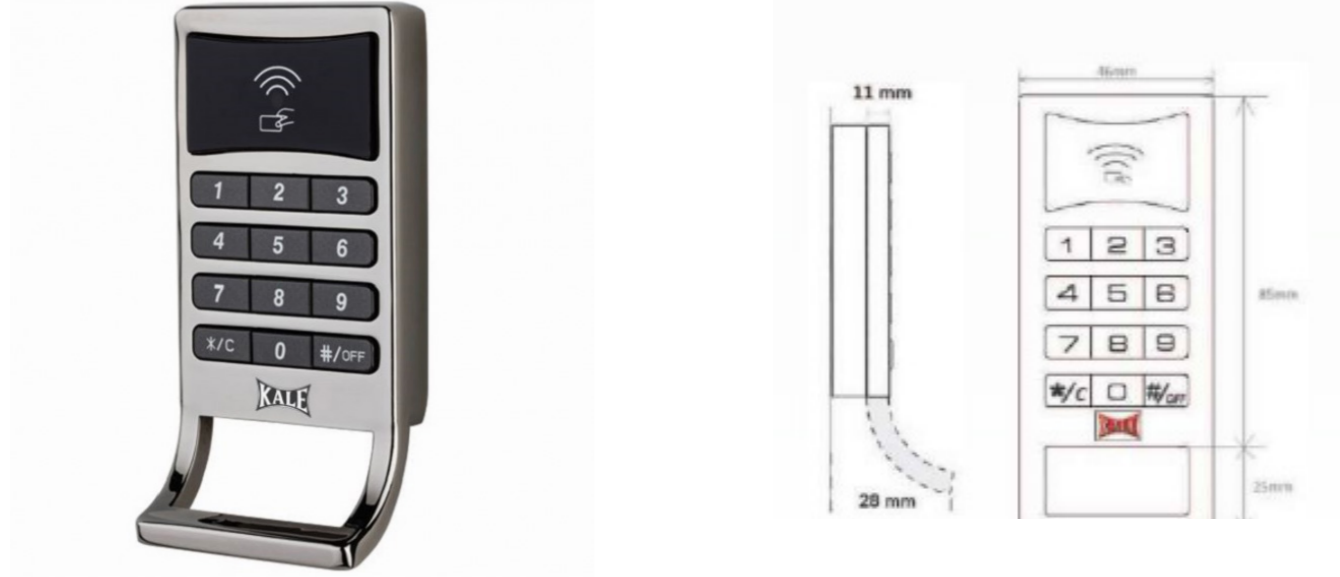

KULLANIM YERİ USAGE	Ahşap Kabin, Dolap uygulamaları Wooden, Steel Cabinet
MATERYAL ANA GÖVDE BODY MATERIAL	Zamak Zinc Alloy
KOD SEVİYESİ CODE LEVELS	3
KOD SEVİYESİ TANIMLARI DESCRIPTION OF CODE LEVELS	1 Yetkilendirme-3 Master-1 Kullanıcı 1 Owner-3 Master-1 User
AÇILMA ŞEKİLLERİ OPENING METHODS	RF Kart & Şifre (Sabit & Geçici) RF Card & User code (Permanent & Temporary)
ID ANAHTAR CİNSİ ID KEYTYPE	RPID+Dijital RPID+Digital
SESSİZ ÇALIŞMA FONKSİYONU SILENT MODE	Var Available
AÇILMA MODU OPENING MODE	<input type="checkbox"/> ID Anahtar ile <input type="checkbox"/> Sadece Sabit Şifre ile <input type="checkbox"/> Sadece Geçici Şifre ile +ID Key +With permanent User code +With temporary User code
KİLİT DURUMU IŞIK UYARISI LOCK STATUS LIGHT WARNING	Kilitli durum sırasında, bu dolabın kullanıldığına dair ikaz vermek için mavi ışık 2 saniyelik süreyle yanıp sönür. When it is locked, the blue light flashes for 2 seconds to give you warning of the cabinet is being used.
OTOMATİK KİLİTLEME AUTOMATIC LOCK	Var Available
YETKİSİZ ANAHTAR YANLIŞ ŞİFRE İLE AÇILMA ALARMI ALARM FOR UNREGISTERED KEY	4 kez yanlış şifre girilmesinde 60 saniye süre ile Alarm gider. 20 saniye sonra sönür. Alarm goes off for 20 second after reading unregistered key 4 times
DÜŞÜK VOLTAJ ALARMI LOW VOLTAGE ALARM	Sesli uyarı ile With sound warning
PİL ÖLÇÜSÜ & ADETLERİ BATTERY SIZE & QTY	AA-3 adet AA-3 pcs
ACİL DURUM AÇILIŞI EMERGENCY OPENING	9V pil ile with 9V battery



Kale Digital Lock

Product Code - KD050/45-106

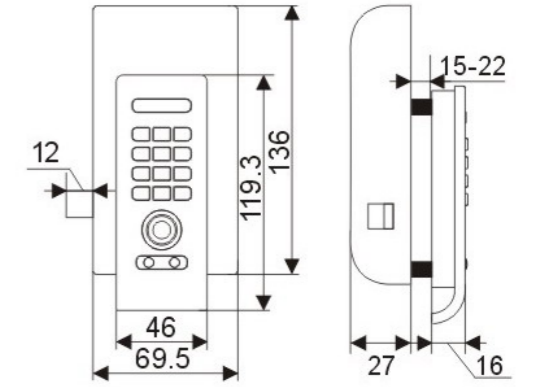

TEKNİK BİLGİLER | TECHNICAL SPECIFICATIONS

KD050/45-106	
KULLANIM YERİ USAGE	Ahşap Kabin, Dolap ve Çekmece uygulamaları Wooden, Steel Cabinet & Drawer
MATERYAL ANA GÖVDE BODY MATERIAL	Alüminyum alaşım Aluminium alloy
RENK COLOR	Gümüş Silver
DIŞ GÖVDE BOYUTLARI DIMENSIONS OF FRONT BODY	95.5(U/L)x58(G/W)x17(Y/H) mm
İÇ GÖVDE BOYUTLARI DIMENSIONS OF REAR BODY	133(U/L)x66(G/W)x27.5(Y/H) mm
ID ANAHTAR YUVASI AYDINLATMASI ID KEY BASE BACKLIGHT	Var Available
KOD SEVİYESİ CODE LEVELS	3
KOD SEVİYESİ TANIMLARI DESCRIPTION OF CODE LEVELS	1 Yetkilendirme-5 Master-1 Kullanıcı 1 Owner-5 Master-1 User
AÇILMA ŞEKİLLERİ OPENING METHODS	ID Anahtar & Şifre (Sabit & Geçici) ID key & user code (permanent & temporary)
ID & EM ANAHTAR CİNSİ TYPE OF ID & EM KEYS	ID 90 & EM 91
SESSİZ ÇALIŞMA FONKSİYONU SILENT MODE	Var Available
AÇILMA MODU OPENING MODE	<input type="checkbox"/> ID Anahtar ile <input type="checkbox"/> ID Anahtar ve Geçici Şifre ile <input type="checkbox"/> Sadece Sabit Şifre ile <input type="checkbox"/> Sadece Geçici Şifre ile * ID Key * ID Key and Temporary User code * With permanent User code * With temporary User code
KULLANIM UYARISI OCCUPIED INDICATOR	Her 3 saniye'de yanıp sönen yeşil ışıklar As blinking green light every 3 seconds
OTOMATİK KİLİTLEME AUTOMATIC LOCK	Var Available
KİLİT ÖMRÜ SERVICE LIFE OF LOCK	90.000 kez açma & kapama 90.000 opening & closing cycle
YETKİSİZ ANAHTARLA AÇILMA ALARMI ALARM FOR UNREGISTERED KEYS	Yetkisiz anahtarın 4 kez okutulmasında 60 saniye süre ile Alarm goes off for 60 second after reading unregistered key 4 times
DÜŞÜK VOLTAJ ALARMI LOW VOLTAGE ALARM	Sesli uyarı ile With sound warning
MANDAL UZUNLUĞU LENGTH OF LATCH	12 mm
KAPI KALINLIĞI DOOR THICKNESS	15-25 mm
PİL ÖLÇÜSÜ & ADETLER BATTERY SIZE & QTY	AA-4 adet/pcs
PİL ÖMRÜ BATTERY LIFE	16.000 kez açma kapama/düşük voltaj uyarısından sonra 100 kez Locking/Unlocking cycle 16.000 times/Operates 100 cycles under low voltage
ACİL DURUM AÇILIŞI EMERGENCY OPENING	Harici pil ünitesi ile 9 V 9 V external battery compartment
STATİK AKIM STATIC CURRENT	<30 uA
DİNAMİK AKIM DYNAMIC CURRENT	<350mA
ALARM VOLTAJ ALARM CRITICAL VOLTAGE	4.2±0.2 V
ÇALIŞMA SICAKLIĞI WORKING TEMPERATURE	-10°C/55°C
ÇALIŞMA NEM ORANI WORKING HUMIDITY	20%-93%
NET AĞIRLIK NET WEIGHT	294.3 gr
BRÜT AĞIRLIK GROSS WEIGHT	327.9 gr

Kale Digital Lock

Product Code - KD050/45-116

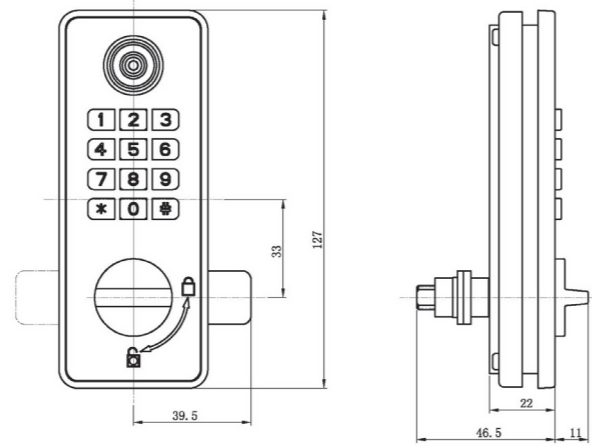

TEKNİK BİLGİLER | TECHNICAL SPECIFICATIONS

KD050/45-116			
KULLANIM YERİ (ENV.)	Klas konutlar ve diğer dış mekan uygulamaları Apartmanlar, oteller, restoranlar, mağazalar.	KİLİT ÇEŞİTİ (LOCK TYPE)	MEKİK KİLİT ÇEŞİTİ (KEYLOCK TYPE)
MONTAJ YERİ VE BİRİMİ (MOUNTING PLACE)	AKS	YETİŞİCİLİK ANAHTARLI AÇILMA ALARMI (ALARM FOR UNEXPECTEDLY OPENING)	Yeterli sesli alarm Alarm goes off for 30 seconds after hearing a ringtone 4 times
RENK COLOR	Sarımsı Gümüş Gold Brass	ÖLÇÜK VE YALNIZLIK (DIMENSIONS)	38x127x46.5 mm (1.5x5.0x1.8 inch)
DEĞİŞİTİRİLEBİLİR REKONSTRÜKTİBİLİTİ (RECONSTRUCTIBLE)	YOK (NO)	MANDAL UZUNLUĞU (LENGTH OF LATCH)	30,5 mm
ID ANAHTAR YUVASI AYDINLATMASI ID KEY BASE ILLUMINATION	Var Available	KAPAK KULLANIMI (COVER USAGE)	0,8x2,5 mm
KİLİT SEVİYESİ (LOCK LEVEL)	3	PL. DÜĞÜMÜ & ADIETLER (BATTERY SIZE & QTY)	AAA (bata) x2 adet/parça
KİLİT SEVİYESİ (KİLİT SEVİYESİ) (LOCK LEVEL (LOCK LEVEL))	1. Yeterli sesli alarm 1. Yeterli sesli alarm	PL. ÖMÜRÜ (BATTERY LIFE)	10000 saat (ortalama) 10000 hours (average)
AGILAMA DÜĞÜMLERİ (DIGIT KEYS)	ID Anahtar & 0 (Sadece & Geçerli) (ID key & 0 (valid & correct))	ACİL DURUM DÜĞÜMÜ (EMERGENCY BUTTON)	Yoktur (not available)
ID & PIN ANAHTAR ÇEŞİTİ (TYPE OF ID & PIN KEY)	ID ve PIN	STATİK AKIM (STATIC CURRENT)	+30 uA
AGILAMA DÜĞÜMÜ (DIGIT KEYS)	ID Anahtar & 0 (Sadece & Geçerli) (ID key & 0 (valid & correct))	DİNAMİK AKIM (DYNAMIC CURRENT)	+350mA
KULLANIM UYARISI (USAGE INDICATOR)	Her 2 saniyede yeşil ışık yanar Light flashes green every 2 seconds	İLAKIM VOLTAJI (OPERATING VOLTAGE)	3,0V DC
OTOMATİK KİLİTLENME (AUTO LOCKING)	Var Available	ÇALIŞMA SICAKLIĞI (WORKING TEMPERATURE)	-20°C/32°F
		ÇALIŞMA NEM ORANI (WORKING HUMIDITY)	95% RH
		NET AĞIRLIK (NET WEIGHT)	200 gr
		KİLİT ÖMÜRÜ (LOCK LIFE)	100000 saat

Hanger System

Product Code - DA 01207

- The product features a diameter of 30x15 mm and a matte anodized hanger profile.
- Following CNC processing, the hanger profile is fixed to the MDF compact laminated body of the locker cabinets, and the hangers do not fall off once the assembly application is accomplished.
- The weight of the goods in this category varies depending on their size.

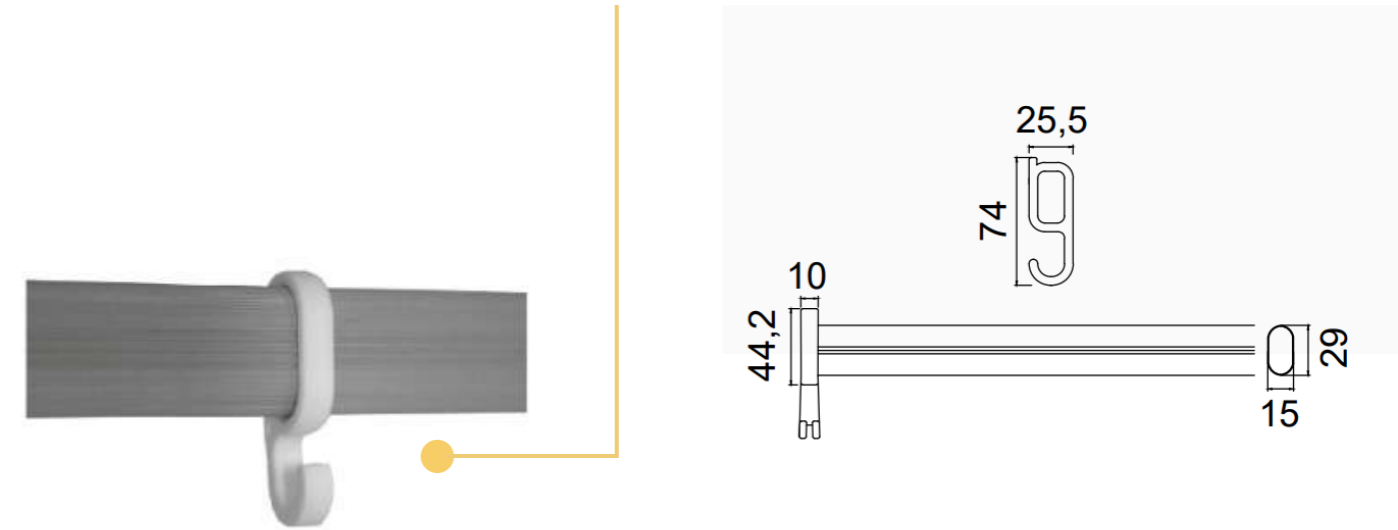

Longevity is buried in the details.

Cabinet hanger plastics include antimicrobial hooks. This feature gives the benefit of long-term use.

CNC Grill

Product Code -DA 01211

- This product was designed to provide air circulation on the locker cabinet doors.
- It is produced in standard size of 40x250 mm.
- It is easy to assemble.
- The weight of this accessory item is 0.095 grams.

 0,095 kg

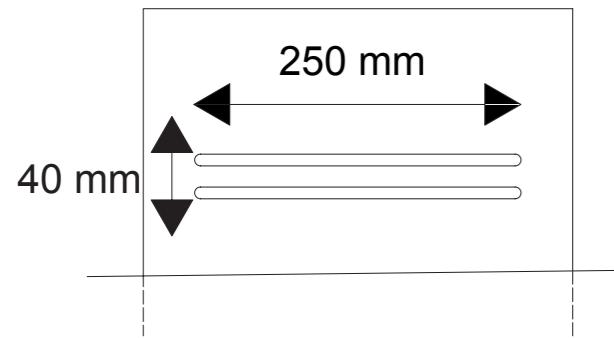

Elegance is in the details.

It offers better features for use regions and a more aesthetically appealing design.



CNC Numerator

Product Code -DA 01211

- This product was developed to facilitate sorting on the locker cabinet doors.
- It is produced in standard size of 40x90 mm.
- It is attached to the mounting surface, which is drilled with CNC machines to fit its size.
- It is easy to assemble.
- The weight of this auxiliary item is 0.095 grams.

 0,095 kg



003

004

005

Plastic Grill

Product Code - DA 01211

- This product was designed to provide air circulation on the locker cabinet doors.
- It is produced in standard size of 40x300 mm.
- It is attached to the mounting surface, which is drilled with CNC machines to fit its size.
- It is easy to assemble.
- The weight of this accessory item is 0.095 grams.

 0,095 kg

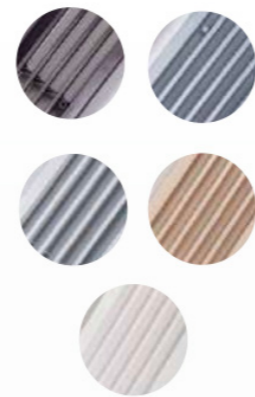
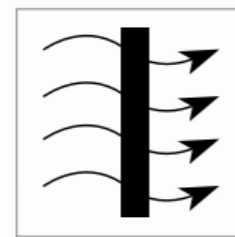
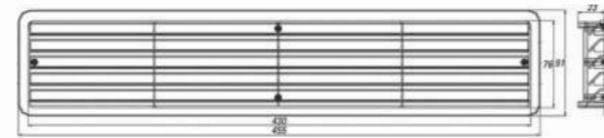

304 Stainless Steel Grip

Product Code - DA 01217

- It is produced of 304 stainless steel.
- It is 35 mm in diameter, and 40 mm in length.
- It has an M8x35 grub screw connection.
- It is not affected by water, humidity and corrosion.
- Its warranty is covered by SANDER's guarantee.

 0,128 kg

Certificate Certificate
CE ISO 9001:2015

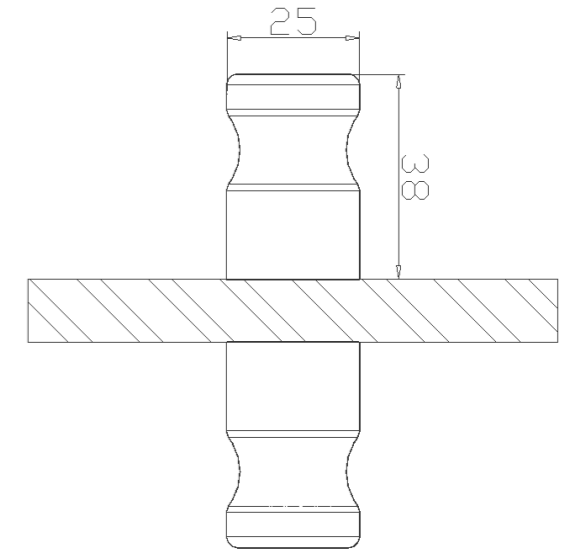
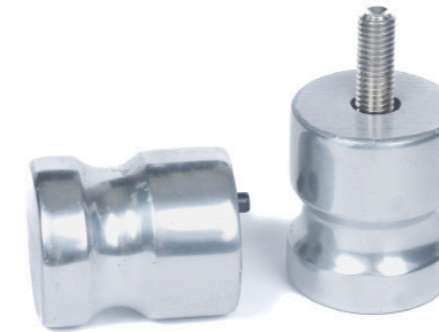

Solid stance is in the details.

After the product is fitted, it allows for +20 mm of movement to alter the floor's squareness.

Aluminum Grip

Product Code - DA 01216

- It is 25 mm in diameter, and 32 mm in length.
- It has an M8x35 grub screw connection.
- It is not affected by water, humidity and corrosion.
- Its warranty is covered by SANDER's guarantee.



0,128 kg

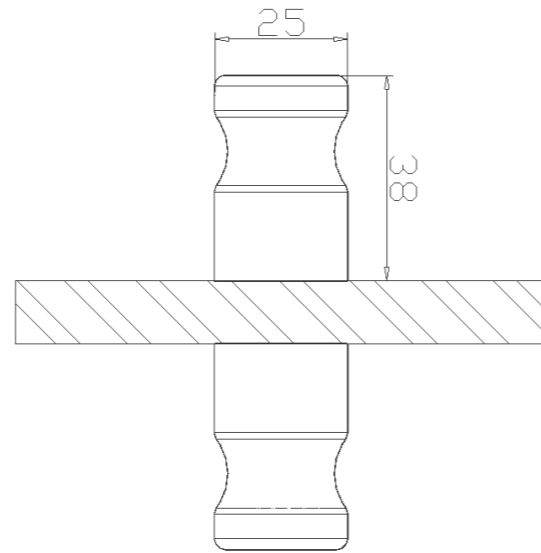
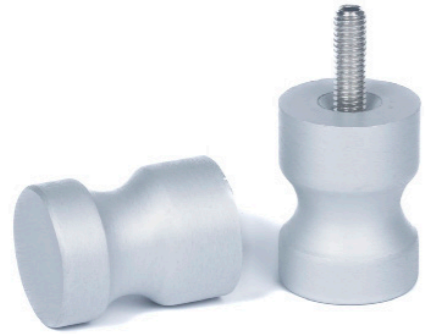

Solid stance is in the details.

After the product is fitted, it allows for +20 mm of movement to alter the floor's squareness.

Hinge for 18 mm MDF

Product Code - DA 01818

- In addition to having flawless design in all of its lines, it also has a small construction and advanced technology. The thin construction of the hinge model, for example, which protrudes just 3 mm from the surface, catches attention. Screw heads are not visible; only sharp lines, smooth surfaces, and rounded lines are seen.

Samet and comparable items are utilized in our typical product pricing.

EASY ASSEMBLY IN FOUR STEPS

- The ergonomic clip-on attachment distinguishes the hinges. The hinge is fitted from the front into the hinge base.
- The hinge base is then audibly fastened by softly pushing the hinge arm with your finger.
- The hinge arm is firmly and without gaps linked to the base at five locations.
- Begin clipping at the top hinge and work your way down. The top hinge bears a portion of the door weight during construction. Disassembly, on the other hand, is done from the bottom up.



 0,210 kg

 
Certificate Certificate
CE ISO 9001:2015



Solid stance is in the details.

The neatly designed linear hinge base is concealed behind the hinge arm. The cup cover latching conceals the perforations.

Hinge for 12 mm Compact Laminate

Product Code - DA 01819

- In addition to having flawless design in all of its lines, it also has a small construction and advanced technology. The thin construction of the hinge model, for example, which protrudes just 3 mm from the surface, catches attention. Screw heads are not visible; only sharp lines, smooth surfaces, and rounded lines are seen.

Samet and comparable items are utilized in our typical product pricing.

EASY ASSEMBLY IN FOUR STEPS

- The ergonomic clip-on attachment distinguishes the hinges. The hinge is fitted from the front into the hinge base.
- The hinge base is then audibly fastened by softly pushing the hinge arm with your finger.
- The hinge arm is firmly and without gaps linked to the base at five locations.
- Begin clipping at the top hinge and work your way down. The top hinge bears a portion of the door weight during construction. Disassembly, on the other hand, is done from the bottom up.



0,210 kg



Solid stance is in the details.

The neatly designed linear hinge base is concealed behind the hinge arm. The cup cover latching conceals the perforations.

Stock Colors

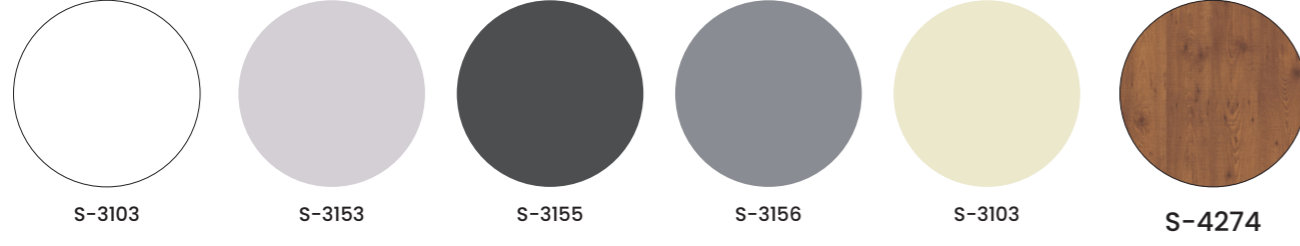

MDF Colors

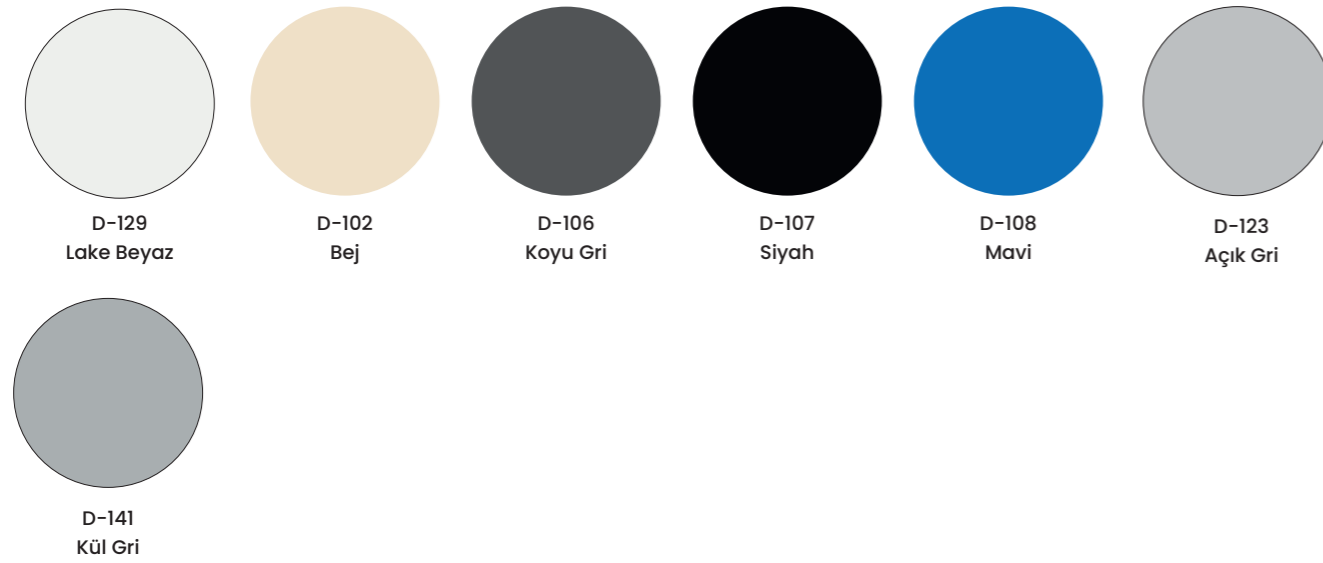

Solid Colors (Out of Stock Production Process 4-8 weeks)

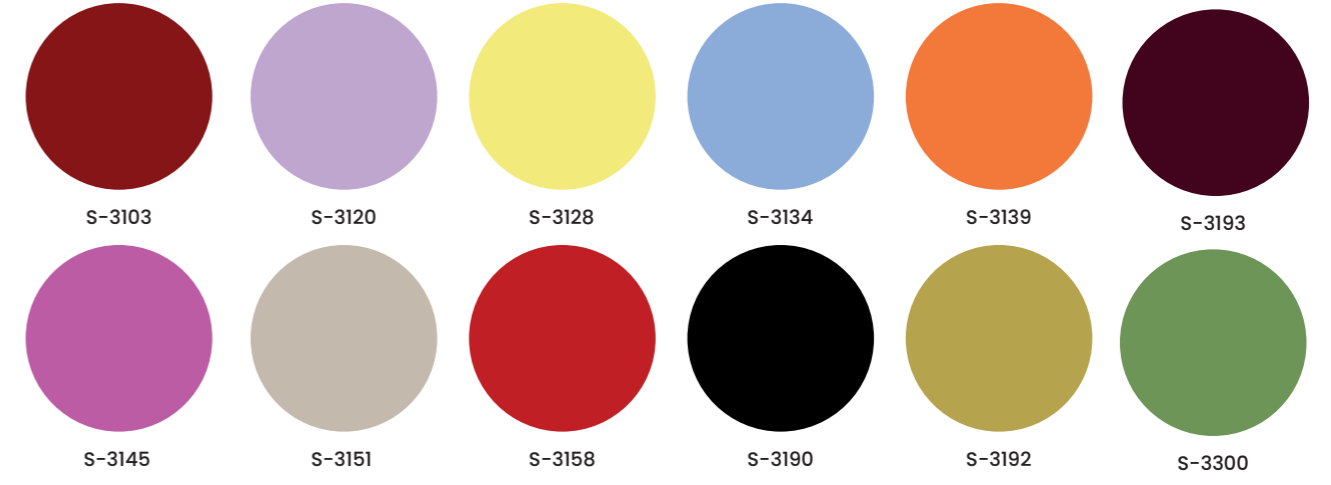

Wood Colors (Out of Stock Production Process 4-8 weeks)

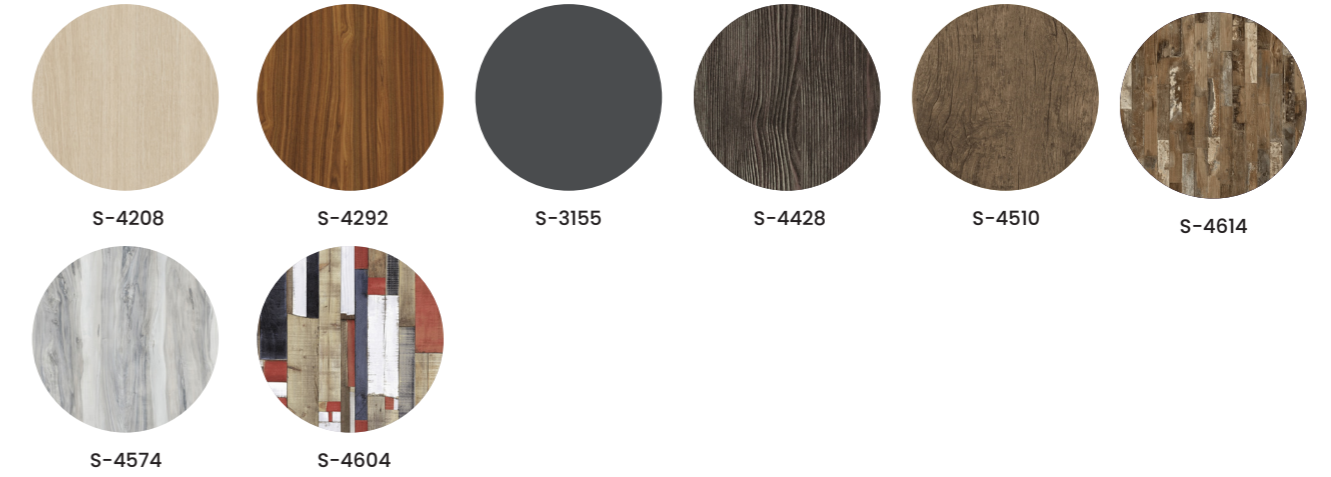

Product Care

Why is maintenance necessary?

It is critical to maintain stainless surfaces in order to maximize product life and corrosion resistance.

What supplies are needed?

This is simply accomplished by dampening a clean cloth in warm water with a tiny bit of detergent or soap.

How to care?

To begin, use a wet cloth to remove coarse grit and grime from the product to be cared for.

Next, thoroughly rinse your cloth. Wiping effectively requires gently rubbing the substance or ingredients.

Attention!

Product maintenance should not be performed using carbon steel brushes or wool wire.



Product Warranty

Warranty

For two years, SANDER guarantees all of its products against corrosion and mechanical flaws.

(*) Our organization accepts no liability in the following situations:

Failure to follow assembly instructions,

In the case of wear and tear caused by maintenance mistakes, in the case of loss or damage caused by user errors, in the case of incorrect disassembly, removal, or replacement, and in the transportations used to carry the product from one location to another.

(**) The right to change

SANDER retains the right to make modifications to standard product features and dimensions without previous notification in order to adhere to the idea of always enhancing service quality.



SANDER

From Turkey to the World, with **environmental,**
ecological, and national values...



SANDER

Adding values to your living spaces



Contact Us

0850 255 39 55



SALES OFFICE

Regus Ofis Park
Merkez Mah. Baęlar Cad. No:14
C2 Blok Zemin Kat, 34406
Kaęthane İstanbul, Türkiye

✉ teklif@sander.com.tr

🌐 www.sanderkabin.com.tr



FACTORY

Mehmet Akif Mah.
Petrol Yolu Cad. No:212 A
Sultanbeyli, İstanbul Türkiye

✉ info@sander.com.tr

🌐 www.sander.com.tr